

RESTRICTED

Crown Copyright Reserved

ARMY CODE No.

61590

Part 7 Supplement 2

DSS (ARMY) 44/8/267

THIS DOCUMENT IS THE PROPERTY OF HER BRITANNIC MAJESTY'S GOVERNMENT, and is issued for the information of such persons only as need to know its contents in the course of their official duties. Any person finding this document should hand it to a Military Unit or Police Station for its safe return to the MINISTRY OF DEFENCE, (DS19b), LONDON, S.W.1., with particulars of how and where found. THE UNAUTHORISED RETENTION OR DESTRUCTION OF THE DOCUMENT IS AN OFFENCE UNDER THE OFFICIAL SECRETS ACTS OF 1911-39.

**USER HANDBOOK
FOR
CLANSMAN RADIO INSTALLATIONS
in TRUCKS, 1/2 and 3/4 ton, FFR and GS,
ROVER**

Part 7 Supplement 2

UK / PRC - 351 / 2
in FFR only

WARNING - RF RADIATION

High power RF radiation can be harmful to your health. The power of the UK/PRC-351/2 is judged to be insufficient to cause ill effects, except when someone is very close to the antenna, coupled with an exposure of several minutes.

Published under the authority of
the Signal Officer - in - Chief (Army), Ministry of Defence

JUNE 1977

RESTRICTED

RESTRICTED

Crown Copyright Reserved

ARMY CODE No.

61590

Part 7 Supplement 2

DSS (ARMY) 44/8/267

THIS DOCUMENT IS THE PROPERTY OF HER BRITANNIC MAJESTY'S GOVERNMENT, and is issued for the information of such persons only as need to know its contents in the course of their official duties. Any person finding this document should hand it to a Military Unit or Police Station for its safe return to the MINISTRY OF DEFENCE, (DS19b), LONDON, S W. 1., with particulars of how and where found. THE UNAUTHORISED RETENTION OR DESTRUCTION OF THE DOCUMENT IS AN OFFENCE UNDER THE OFFICIAL SECRETS ACTS OF 1911-39.

**USER HANDBOOK
FOR
CLANSMAN RADIO INSTALLATIONS
in TRUCKS, 1/2 and 3/4 ton, FFR and GS,
ROVER**

Part 7 Supplement 2

UK / PRC - 351 / 2
in FFR only

WARNING - RF RADIATION

High power RF radiation can be harmful to your health. The power of the UK/PRC-351/2 is judged to be insufficient to cause ill effects, except when someone is very close to the antenna, coupled with an exposure of several minutes.

Published under the authority of
the Signal Officer - in - Chief (Army), Ministry of Defence

JUNE 1977

RESTRICTED

This supplement details the installation of Radio Station UK/PRC-351/2 into trucks $\frac{1}{2}$ and $\frac{3}{4}$ ton FFR Rover. Operating instructions are not included.

ASSOCIATED PUBLICATIONS

The following are applicable to this installation:-

MOD (ARMY) User Handbooks

User Handbook Radio Station UK/PRC-351/2	-	Army Code 61128
User Handbook CLANSMAN condition test set	-	Army Code 61655

Note...

In this supplement the terms 'Equipment rack' and 'Radio table' are applied not only to the $\frac{3}{4}$ ton FFR vehicle items but also to the module rack and module table which are part of the $\frac{1}{2}$ ton FFR vehicle dismountable module.

SUPPLEMENT 2

THE INSTALLATION OF RADIO STATIONS UK/PRC-351/2 INTO TRUCKS, $\frac{1}{2}$ and $\frac{3}{4}$ TON, FFR, ROVER

CONTENTS

	Page
Associated publications	ii
SECTION 1 INTRODUCTION	
The installation	1
Contents of kits	3
Modifications to vehicle	7
Fitted for radio (FFR) vehicles	8
Equipment power supplies	8
Battery lead fitting and removal	10
SECTION 2 INSTALLATION	
General	11
Radio set	12
Initiate box and DCCU	13
Wingmirrors	15
Wing-mounted equipment	16
Power supplies	20
Interconnections	22
Bonding	24
SECTION 3 TESTING	
Testing the installation	24
Testing the radio equipment	24

ILLUSTRATIONS

Fig.		
1	UK/PRC-352 installed in truck, $\frac{3}{4}$ ton, FFR, Rover	iv
2	Repositioning of wingmirrors	6
3	Modifications to bulkhead	7
4	Radio battery connections: $\frac{3}{4}$ ton FFR	8
5	Radio battery connections: $\frac{1}{2}$ ton FFR	9
6	Use of spring washers	11
7	Fitting of plate, mounting to equipment rack	13
8	Initiate box mounting	14
9	Reinforcing channel	15
10	Case, tuner, RF with TUAAM and antenna equipment installed	17
11	TUAAM mountings	18
12	Securing of wing-mounted equipments	19
13	Distribution box: FFR	20
14	Block schematic	23

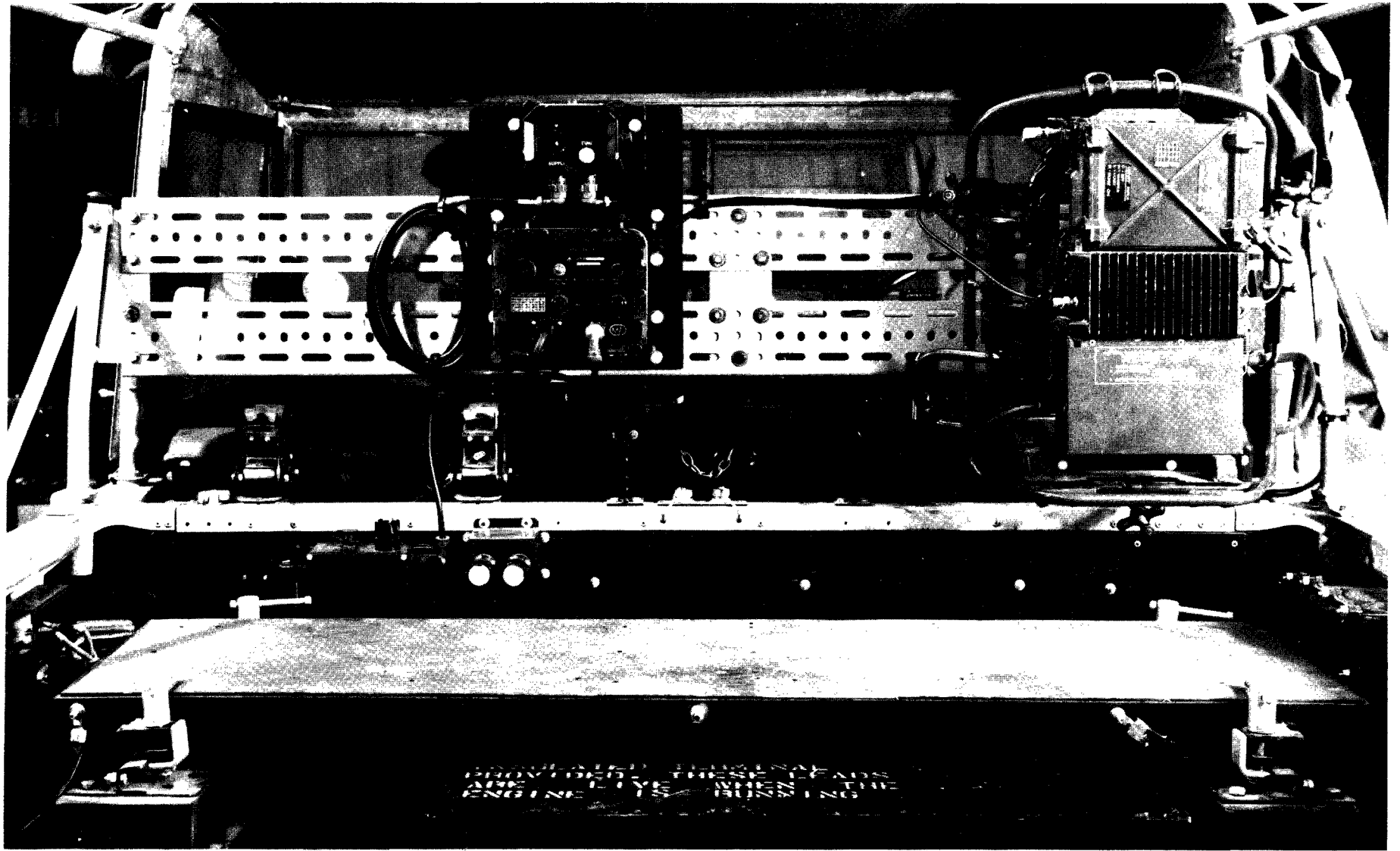

Fig. 1 UK/PRG-352 installed in truck, $\frac{3}{4}$ ton, FFR, Rover

Section 1 INTRODUCTION

THE INSTALLATION

1.1 All the items required for this installation are provided as CLANSMAN $\frac{1}{2}$ and $\frac{3}{4}$ ton Rover 'brick' kits. The bricks appropriate to this installation are listed below.

CLANSMAN $\frac{1}{2}$ and $\frac{3}{4}$ ton Rover 'brick' kits required

Kit	CES	Function
I.K. distribution box Landrover FFR	44661	Provides fused distribution box
C.I.K. UK/PRC-351/2 in FFR vehicles	44656	The radio equipment installation kit
Kit battery charger 28V	43743	Provides DCCU for charging radio set battery
Radio station UK/PRC-351	43753	Basic radio kit
Amplifier RF 20w	43756	Converts UK/PRC-351 to UK/PRC-352

Note: C.I.K. = Clip-in kit I.K. = Installation kit

This supplement contains installation instructions for all these kits. A full description of radio station UK/PRC-351/2, together with operating instructions is given in user handbook Army Code 61128.

NOTE

**The right and left hand sides of the vehicle
are those which would be assumed by a person
sitting normally in the driver's seat.**

1.2 The frame, electrical equipment, which the radio set and frame packboard clip onto, may be secured to either end of the equipment rack. The antenna and associated equipment may be mounted on either front wing. The preferred position for the radio in a single set installation is on the righthand end of the rack. When the set is part of a multiset installation however the number of available positions for both radio and antenna equipment will be restricted. Suitable positions for use in multiset installations are listed in Part 8 supplement 1 together with any special instructions. A direct current charging unit (DCCU) is provided to maintain the rechargeable battery of the radio set. The battery charger is powered from the vehicle's radio batteries. It is secured to the equipment rack via a plate, mounting, which also provides a mounting for the initiate box, associated with the wing-mounted TUAAM. The basic radio set is RT-351 which by the addition of a 20w RF amplifier is converted to RT-352. Under some circumstances either radio may be fitted with a SURF 4w. However this must not be connected electrically as the TUAAM fulfills its function in this installation.

**In this role the surf 4w, if fitted,
must never be electrically con-
nected to the radio.**

1.3 Before attempting to install the kits ensure that they are complete (Para 1.4) and that all appropriate modifications are embodied in the vehicle (Para 1.5). In general, nuts, bolts etc. for main items will be found in linen bags tied to the item. Nut and bolt pairs will usually be supplied with two plain washers and one spring washer.

CONTENTS OF KITS

1.4 The main items of the kits are listed below and at the head of the appropriate installation instructions in the next section. Nuts, bolts and washers are not referred to. For a complete list of kit parts refer to the appropriate CES (See para 1.1).

Main items of kits

A. Installation kit distribution box, GLANSMAN radio in FFR vehicles

Item	Name	NATO Stock No.	Qty	Remarks
1	Distribution box	6110-99-637-9550	1	
2	Bracket, angle	5340-99-637-9551	1	½ ton vehicles only
3	Gasket rubber	5820-99-119-2019	2	
4	Cartridge fuselink 15 amp ferrule contact size 1	5920-99-059-0147	6	not used in this installation

All cable clips, nuts, bolts and washers are stowed in a linen bag together with items 2, 3 and 4. The linen bag is attached to item 1.

B. Clip-in kit UK/PRG-351/2 in FFR vehicles

Item	Name	NATO Stock No.	Qty	Remarks
1	Frame, electrical equipment	5820-99-620-9619	1	attaching parts in linen bag
2	Plate, mounting	5820-99-637-0882	1	associated parts in linen bag
3	Initiate box	5820-99-630-6488	1	
4	Gasket rubber	5820-99-119-2019	2	

/cont.

B. (continued)

Item	Name	NATO Stock No.	Qty	Remarks
5	Case, tuner, RF	5820-99-637-0735	1	associated parts in linen bag
A	Washer, special	5310-99-637-0737	1	
B	Channel	5340-99-620-9665	1	for repositioning wingmirror, may not be required
C	Grommet	5325-99-631-4587	2	to blank unused cable entries
D	Plate, stud mounting	5340-99-645-0002	2)
E	Stud	5307-99-645-0003	4)
F	Bushing, rubber	5365-99-949-1043	4) for mounting TUAAM
G	Bushing, rubber	5365-99-949-1084	1)
H	Lead, electrical	5995-99-637-9886	1	bonds TUAAM to case, tuner RF
J	Cable assy. RF	5995-99-645-0100	1	matching unit to TUAAM
6	TUAAM	5821-99-630-6156	1	
7	Base, antenna element c/w matching unit	5985-99-630-6495	1	
8	Case antenna element	5985-99-637-0806	1	stows items 9 & 10
9	Antenna element 1m x 9.5mm dia	5985-99-630-8456	2	one stowed
10	Antenna element 1m x 6.25mm dia	5985-99-630-8457	2	one stowed
11	Cable assy. power elect.	5995-99-637-9887	1))) see fig. 14
12	Cable assy. power elect.	5995-99-637-0914	1))
13	Clip, adjustable rivet RC2	5340-99-138-3495	8	stowed in linen bag attached to item 11
14	Cartridge fuselink 3 amp ferrule contact size 1	5920-99-059-0143	3	for distribution box

C. Amplifier RF 20w

Item	Name	NATO Stock No.	Qty	Remarks
1	Amplifier RF 20w	5820-99-114-3640	1	
2	Cable assy. RF	5995-99-620-8026	1	connects item 1 to RT-351

D. 28V DCCU

Item	Name	NATO Stock No.	Qty	Remarks
1	Charger battery DC.28V	6130-99-117-0450	1	referred to as DCCU in this supplement
2	Cable assy. power electrical 4 cond. 1m long	5995-99-117-7436	1	DCCU to radio set battery
3	Cable assy. power electrical 2 cond. 2m long	5995-99-117-7437	1	not used

E. Radio station UK/PRC-351 (basic)

Item	Name	NATO Stock No.	Qty	Remarks
1	Transmitter-receiver RT-351	5820-99-114-3639	1	basic radio
2	Bag ancillaries	5820-99-621-9028	1	
3	Handset	5965-99-620-5669	1	
4	Headset	5965-99-620-8320	1	
5	Cable assy. switch elect.	5965-99-620-5667	1	
6	Frame, packboard	8465-99-135-7135	1	
7	Plate adaptor carrier	5820-99-645-0133	1	
8	Battery, alkaline secondary 3.3AH	6140-99-620-8057	3	two spare

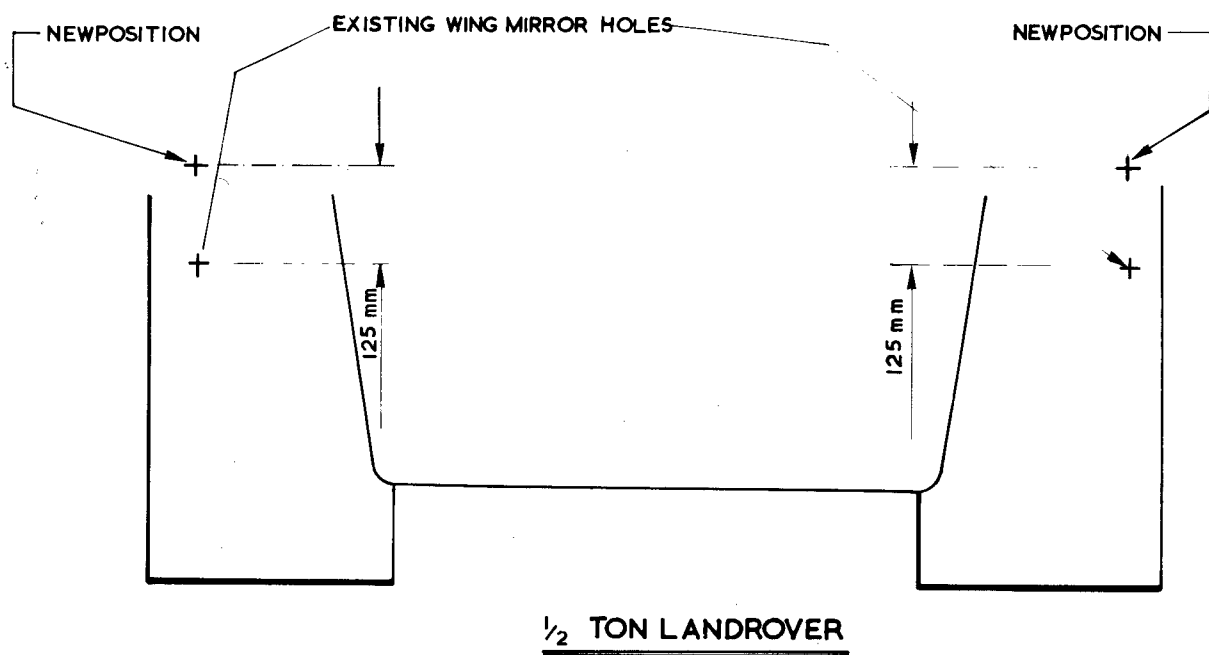
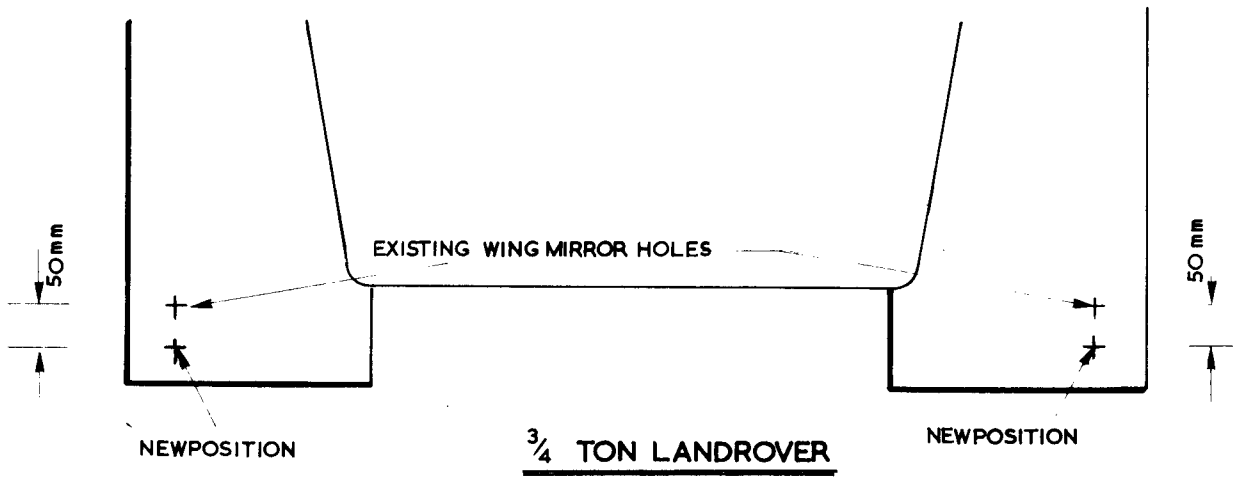

Fig. 2 Repositioning of wingmirrors

MODIFICATIONS TO VEHICLE

1.6 The following modifications are necessary to the vehicle to enable the radio station to be installed. This does NOT constitute authority to embody these modifications.

1. If wing-mounted rear view mirrors are fitted the front wings should be drilled as in fig. 2 to allow relocation of the appropriate mirror to clear the case, tuner, RF.
2. The bulkhead behind the lefthand front seat should be drilled to accept the distribution box ($\frac{3}{4}$ ton) or its mounting bracket ($\frac{1}{2}$ ton). In $\frac{3}{4}$ ton vehicles it is essential that the cable securing screw has its head toward the rear. See fig. 3.
3. The cable and conduit assemblies should be installed from each front wing to the equipment rack.

These modifications are detailed in EMER Wheeled Vehicles Q 027 mod. instructions Nos. 62 and 65 ($\frac{1}{2}$ ton) or 63 and 64 ($\frac{3}{4}$ ton).

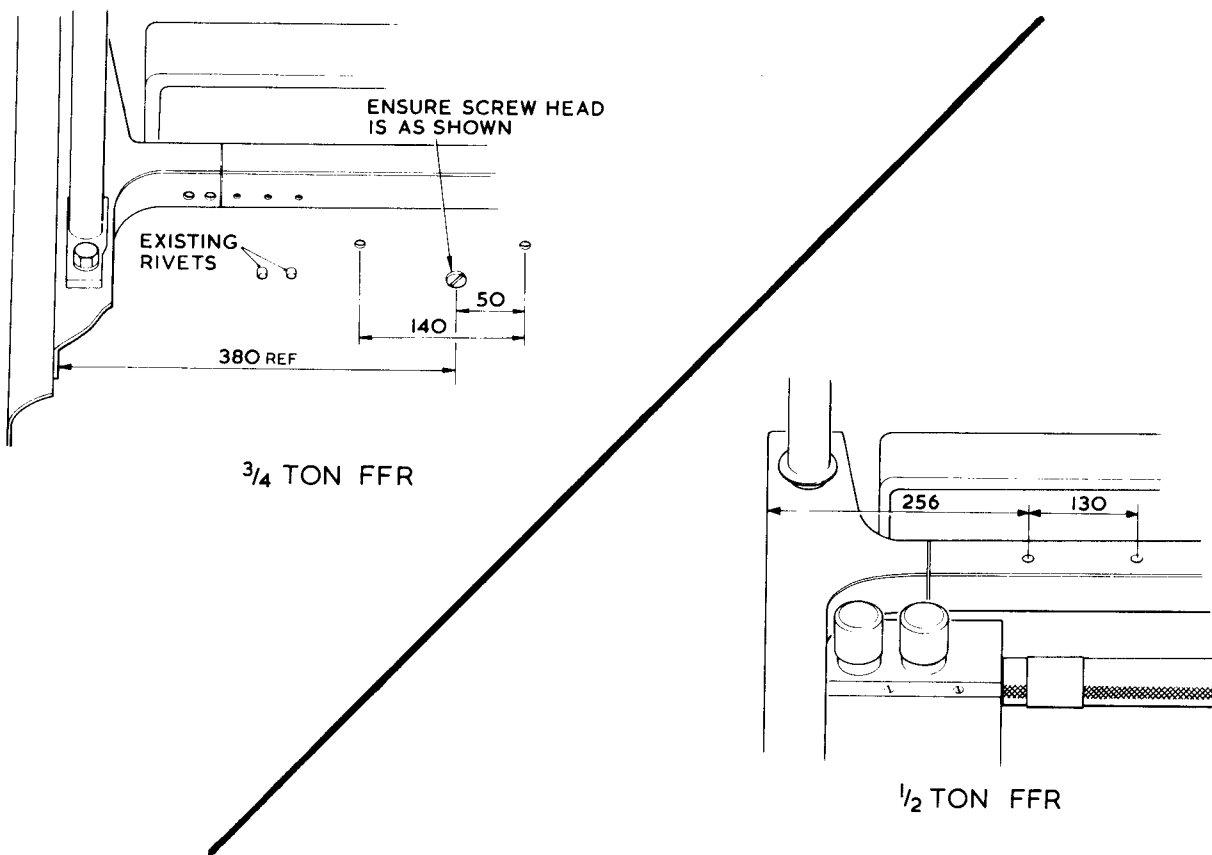

Fig. 3 Modifications to bulkhead

FITTED FOR RADIO (FFR) VEHICLES

1.6 These are specially equipped vehicles, being provided with a 24V power supply, radio table, equipment rack, extra batteries, antenna mounting and special cabling to facilitate fitting and operation of radio equipment. In $\frac{3}{4}$ ton vehicles the radio table and equipment rack, extra batteries, and antenna mountings are bolted to the vehicle body. In $\frac{1}{2}$ ton vehicles these items are assembled in the form of a dismantable module.

EQUIPMENT POWER SUPPLIES

1.7 Normally two 12V, 100Ah batteries will be provided, connected in series to give 24V and charged from the vehicle when the engine is running. For some multiset installations an extra pair of batteries wired in parallel to the first pair may be employed. In $\frac{3}{4}$ ton vehicles one pair of 'screw down' terminals are provided on top of a vehicle terminal box in the front lefthand corner of the rear compartment. These terminals are labelled 'RADIO' and the distribution box is to be connected to them. Another pair of terminals - insulated and coloured white are provided on the bulkhead. These are to stow the leads from the vehicle power supply to the batteries if the vehicle engine is to be started with the leads disconnected from the batteries. Some earlier $\frac{3}{4}$ ton vehicles have two pairs of terminals in the front lefthand corner, one pair marked 'EQPT' the other 'BTY.' The distribution box should be connected to the 'EQPT' pair.

Note...

The negative lead to the radio batteries is internally earthed to the vehicle chassis.

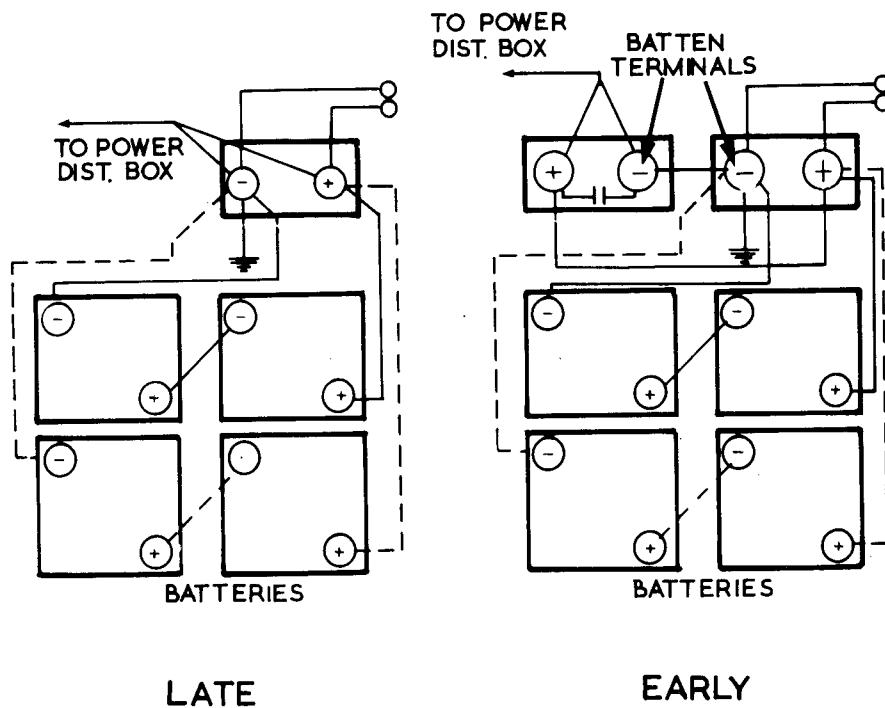

Fig. 4 Radio battery connections: $\frac{3}{4}$ ton FFR

1.8 There are three pairs of terminals fitted to the module in $\frac{1}{2}$ ton vehicles and these are connected to the three fixed plugs in the battery compartment. Two of these pairs of terminals are further wired to a plug on the back of the module. Connection to the vehicle power supply is made at this point via a cable which connects with a fixed plug on the bulkhead behind the seats. The third pair of terminals is completely isolated from the vehicle power supply and is marked ISOLATED and mounted on a white base. The corresponding fixed plug in the battery compartment is also mounted on a white base. Either two or four batteries should be fitted. These are mounted one pair to each battery tray. Each pair of batteries is connected to a harness terminated with a free socket which should be connected to one of the fixed plugs in the battery compartment. With the engine running and connecting cable in place batteries connected to the non-isolated plugs will be charged. In this application the batteries must be connected to the non-isolated side. A diagram of connections is on the inside of the battery compartment lid. It may be necessary to open the tailboard and remove the seats to fully open the battery compartment lid.

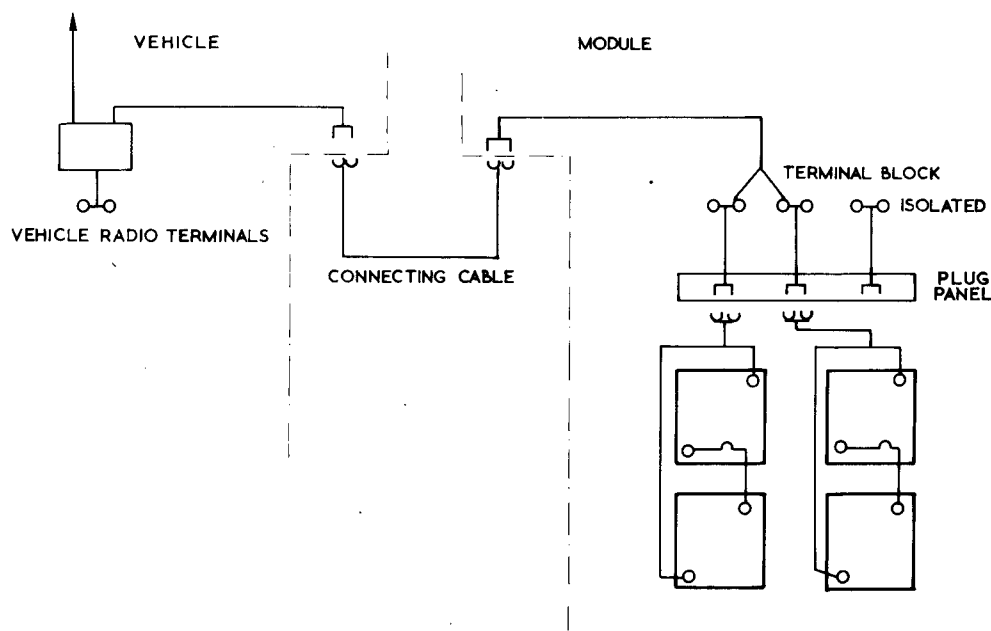

Fig. 5 Radio battery connections: $\frac{1}{2}$ ton FFR

1.9 The $\frac{1}{2}$ ton vehicle has one pair of terminals installed in the front lefthand of the rear compartment as in $\frac{3}{4}$ ton vehicles. If the connecting cable between the module and the cable is not in place these terminals are only live when the engine is running.

CAUTIONS...

1. There are live terminals behind the battery box hinged panel.
2. ALWAYS unplug the batteries from the module FIRST when disconnecting them in $\frac{1}{2}$ ton vehicles.

IMPORTANT

ALWAYS stow the lug ends of the battery leads on insulated terminals when not fitted to the battery. Should the engine be started with the positive lead in contact with the metal parts of the body the vehicle generator output will be shortcircuited.

ALWAYS disconnect the series connector from the batteries FIRST when disconnecting batteries.

1.10 If for any reason battery leads have to be removed from the batteries in any vehicle the following order must be observed:-

- (1) Remove the series connector from the batteries.
- (2) Remove the positive connector and stow on one insulated terminal.
- (3) Remove the negative connector and stow on the other insulated terminal.

Connection of batteries should be accomplished in the reverse order.

IMPORTANT

Make sure that power leads are connected positive to positive and negative to negative throughout. If polarity is reversed the equipment may be damaged.

Section 2 INSTALLATION

GENERAL

2.1 This procedure involves the fitting of all the kits listed in para 1.1. If one or more of the kits are already installed it may simplify installation of the remainder if certain items are temporarily removed. Plain and spring washers are provided with the nuts and bolts used in the installation of the kits. Unless otherwise stated these plain and spring washers are to be used as follows:-

1. Where nuts and bolts are used together: (fig. 6A) Fit a plain washer onto the bolt. Pass the bolt through the items to be secured together. Fit another plain washer to the protruding end of the bolt. Fit the spring washer and the nut. Tighten the nut and bolt with a pair of spanners by holding the bolthead with one spanner and turning the nut with the second.
2. Where a bolt screws into an item: (fig. 6B) Fit the spring washer onto the bolt, then a plain washer. Pass the bolt through the item to be secured and screw the bolt into the other item. Tighten the bolt up firmly.
3. Where a nut screws onto a threaded extension of an item: (fig. 6C) Fit the item to be secured over the threaded extension. Fit a plain washer over the protruding threaded extension. Fit the spring washer and the nut. Tighten the nut up firmly.

When the kits are assembled correctly at least $1\frac{1}{2}$ turns of screw thread will protrude through each nut used.

The following applies to all vehicles unless otherwise stated.

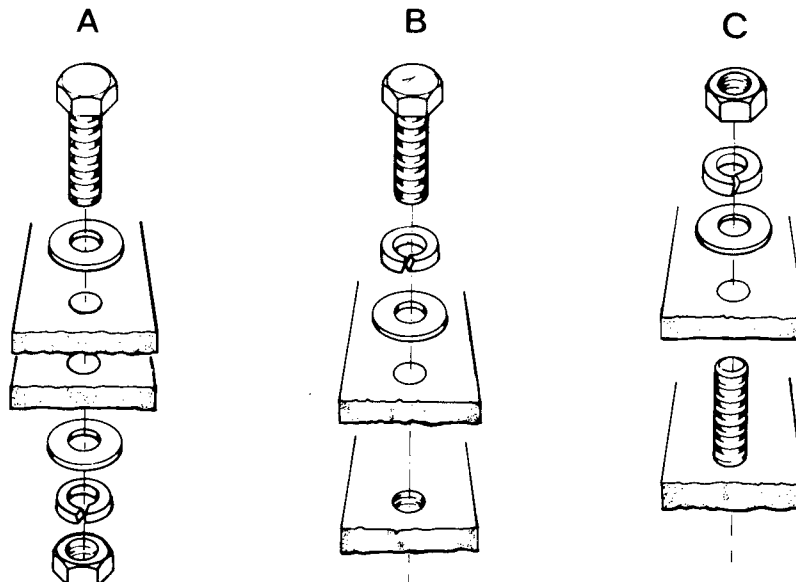

Fig. 6 Use of spring washers

RADIO SET

2.2 Items required

Name	NATO Stock No.	Qty	Remarks
Frame, electrical equipment	5820-99-620-9619	1	attaching parts stowed in linen bag
Transmitter receiver RT-351	5820-99-114-3639	1	
Amplifier, RF 20w	5820-99-114-3640	1))) if required
Cable assembly RF	5995-99-620-8026	1))

1. Bolt the frame, electrical equipment (5820-99-620-9619) to either end of the equipment rack using the M8 nuts, bolts and washers stowed in the linen bag attached to the frame, electrical equipment.

2. Clip the manpack carrier with the radio set attached to the frame, electrical equipment and secure using the three handwheel-operated J-bolts.

Note...

The radio set must be secured to its frame, packboard which is part of the basic radio station. Instructions for this are given in the radio station user handbook Army Code 61128, together with installation instructions for the amplifier RF 20w if this is to be used.

In this role the surf 4w, if fitted, must never be electrically connected to the radio.

INITIATE BOX AND DCCU

2.3 Items required

Name	NATO Stock No.	Qty	Remarks
Plate, mounting	5820-99-637-0882	1	attaching parts stowed in linen bag
Initiate box	5820-99-630-6488	1	
DCCU 28V	6130-99-117-0450	1	attaching parts stowed in linen bag attached to plate, mounting
Gasket rubber	5820-99-119-2019	2	

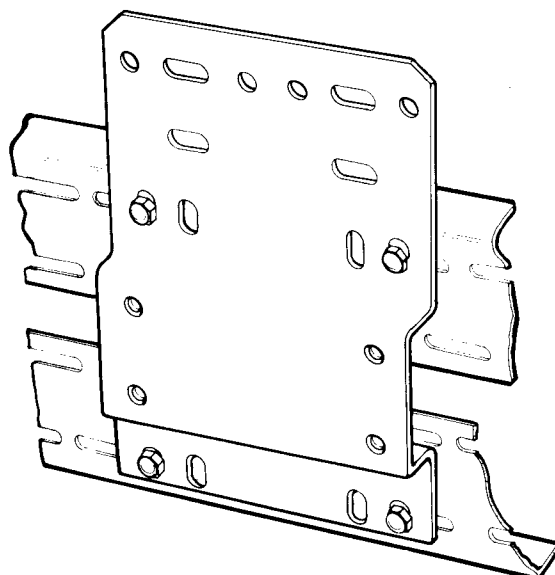

Fig. 7 Fitting of plate, mounting to equipment rack

1. Bolt the plate, mounting (5820-99-637-0882) to a convenient position on the equipment rack adjacent to the radio as in fig. 7 using 4 off M8 x 20mm bolts, nuts and washers from the attached linen bag. This position must be such that the one metre cable from the DCCU will easily reach the radio set.

CAUTION...

THE CABLE INTERCONNECTING THE DCCU AND THE RADIO SET BATTERY IS A FIXED ONE METRE LENGTH AND UNDER NO CIRCUMSTANCES MAY IT BE EITHER LENGTHENED OR SHORTENED.

2. Bolt the DCCU to the plate, mounting using 4 off M8 x 25mm bolts and washers from the linen bag attached to the plate, mounting.
3. Bolt the initiate box to the plate, mounting as in fig. 8 using 2 off gaskets (5820-99-119-2019), 2 off M8 x 35 bolts, nuts and washers from the linen bag attached to the plate, mounting.

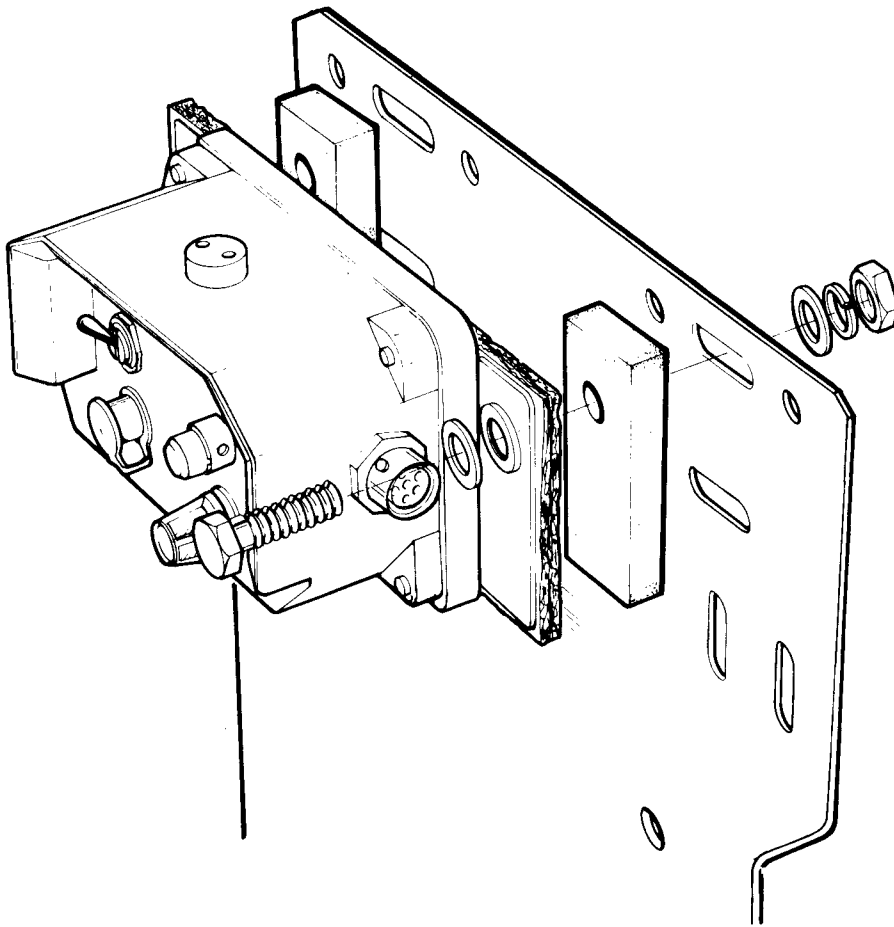

Fig. 8 Initiate box mounting

WINGMIRRORS

Note...

Certain vehicles may be fitted with wing-mounted rear view mirrors and in order to fit the case, tuner, RF, one of these will require repositioning. Fig. 2 shows both new and old positions.

2.4 Item required

Name	NATO Stock No.	Qty	Remarks
Channel	5340-99-620-9665	1	stowed in linen bag attached to case, tuner, RF

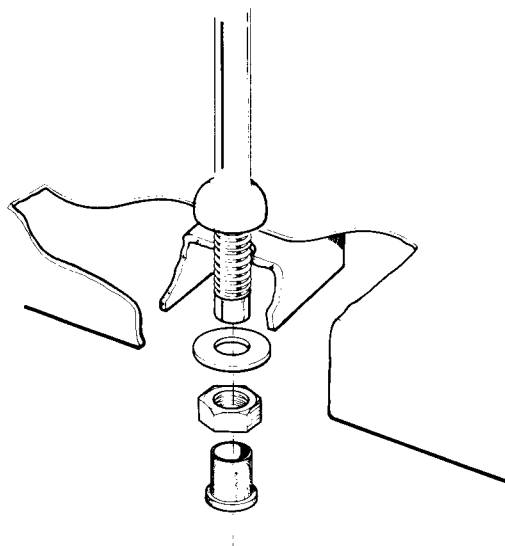

Fig. 9 Reinforcing channel

1. Remove and retain the protective sleeve from the underwing portion of the mirror.
2. Unscrew the nut securing the wingmirror to the wing, retaining the nut and washers.
3. Secure the wingmirror to the wing in the new position with the original nut and washers using the channel, reinforcing as indicated in fig. 9.
4. Refit the protective sleeve to the underwing portion of the wingmirror.

WING-MOUNTED EQUIPMENT

2.5 Items required

Name	NATO Stock No.	Qty	Remarks
Case, tuner, RF	5820-99-637-0735	1	all associated items stowed in attached linen bag
ASSOCIATED ITEMS			
Washer, special	5310-99-637-0737	1	
Channel	5340-99-620-9665	1	for repositioning wingmirror See para 2.4
Grommet	5325-99-531-4587	2	to blank unused cable entries
Plate, stud mounting	5340-99-645-0002	2)
Stud	5307-99-645-0003	4)) for mounting) TUAAM
Bushing, rubber	5365-99-949-1043	4)
Bushing, rubber	5365-99-949-1084	4)
Lead, electrical	5995-99-637-9886	1	bonds TUAAM to case, tuner RF
Cable assy. RF	5995-99-645-0100	1	matching unit to TUAAM
Base antenna element c/w matching unit	5985-99-630-6495	1	
Tuning unit, automatic antenna matching (TUAAM)	5821-99-630-6156	1	
Antenna element 1m x 9.5mm dia	5895-99-630-8456	1	
Antenna element 1m x 6.25mm dia	5895-99-630-8457	1	

Note...

The 4 off studs (5307-99-645-0003) and 2 off plates, stud (5340-99-645-0002) are supplied already assembled as 2 off mounting plate assemblies and are referred to as such in the following paragraphs. The studs are bonded into the plates and no attempt should be made to separate them.

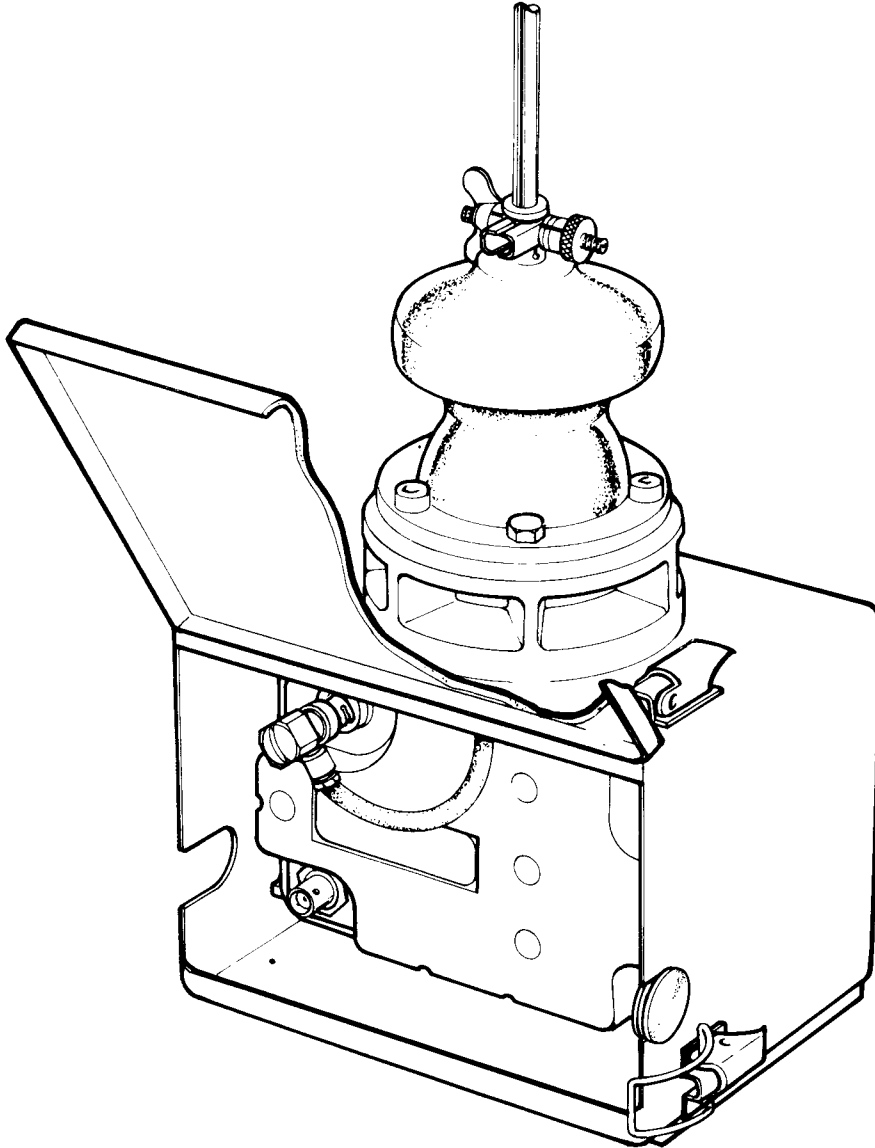

Fig. 10 Case, tuner, RF with TUAAM and antenna equipment installed

POWER SUPPLIES

2.6 Items required

Item	Name	NATO Stock No.	Qty	Remarks
1	Distribution box	6110-99-637-9550	1	
2	Bracket, angle	5340-99-637-9551	1	½ ton vehicles only
3	Gasket	5820-99-119-2019	2	
4	Cartridge fuselink 3 amp ferrule contact size 1	5920-99-059-0143	3	from clip in kit UK/PRG-351/2 in FFR vehicles

All cable clips, nuts, bolts and washers are stowed in a linen bag together with items 2, 3 and 4. The linen bag is attached to item 1.

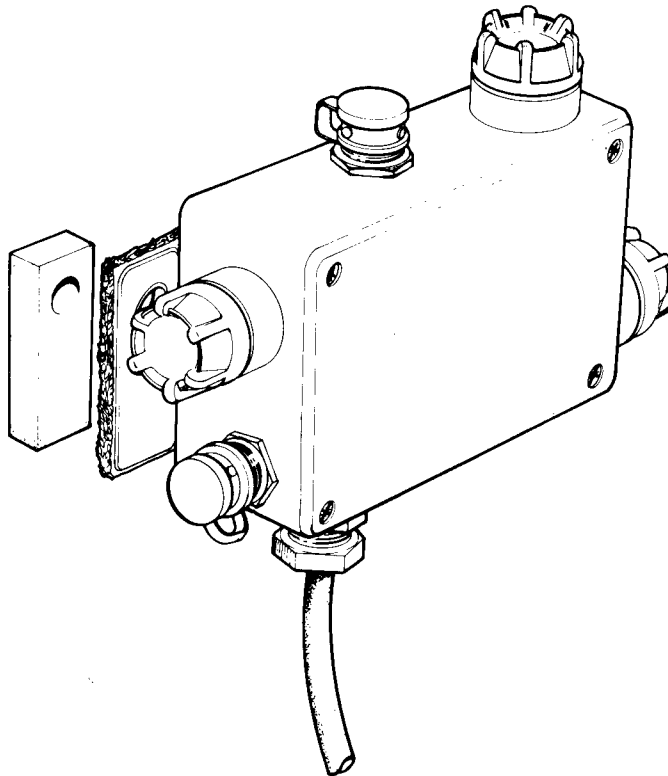

Fig. 13 Distribution box: FFR

1. Fit the three 3-amp fuses from the linen bag attached to the distribution box (6110-99-637-9550) into the fuse holders.
2. $\frac{1}{2}$ ton vehicles only: Secure the bracket angle (5340-99-637-9551) to the bulkhead behind the passenger seat on the lefthand side using 2 off M8 screws (20mm long) nuts and washers from the linen bag.
3. Secure the distribution box with the cable entry underneath either either to the bracket angle in $\frac{1}{2}$ ton vehicles or direct to the bulkhead behind the passenger seat on the lefthand side in $\frac{3}{4}$ ton vehicles. Use 2 off M8 bolts (35mm long) nuts and washers with gaskets (5820-99-109-2019) to space the box away from the bracket or bulkhead.
4. Connect the lead from the box to the FFR 'RADIO' terminals. Clip the lead to the equipment rack using the clips (5340-99-138-3495) provided.

IMPORTANT

Make sure that power leads are connected positive to positive and negative to negative throughout. If polarity is reversed the equipment may be damaged.

INTERCONNECTIONS

2.7 These are shown in the block schematic fig. 14. All cables are to be clipped to the equipment rack or vehicle, as appropriate, to ensure that there is no possibility of damage to the cables. Clips for this purpose are stowed in a linen bag attached to cable assembly, power, electrical (5995-99-637-9887).

1. Remove the cable ends from the connector stowage box on the appropriate wing. Remove the blanking grommet from the case, tuner, RF, cable entry nearest the connector stowage box. Connect the coaxial cable to TUAAM socket ISK2 and the 7-core cable to TUAAM socket ISK1. Close the lid and fit the locking pins to the catches.

Note...

When the case, tuner, RF is removed from the vehicle wing the cables must be replaced in the stowage box. The plugs on the ends of the cable and the sockets on the TUAAM MUST be protected with dustcaps.

2. Connect the coaxial lead from the wing-mounted equipment to the coaxial socket on the amplifier, RF 20w, if fitted, or to the coaxial socket on the RT-351. This cable is already installed in the vehicle and is stowed in an open box behind the front seat.
3. Connect the other cable from the wing-mounted equipment to the socket marked ATU on the initiate box.
4. Using cable assembly, power, electrical (5995-99-637-0914) connect the socket marked MANPACK on the initiate box to SK2 on radio set RT-351.
5. Connect the DCCU to the radio set's battery using cable assembly, power, electrical (5995-99-117-7436) provided with the DCCU.

CAUTION...

Cable assembly, power, electrical (5995-99-117-7436) as supplied is one metre long. This cable is to be neither lengthened nor shortened.

6. Make sure that the INPUT switch on the DCCU is set to OFF.

Note...

When the distribution box is connected to the FFR 'RADIO' terminals the three outlet sockets are LIVE.

Connect the DCCU to a 2-pin socket on the distribution box using cable assembly, power, electrical (5995-99-637-9887).

Connectors

Ref	Description	NATO Stock No.	From	To
101	Cable assy. RF	5995-99-637-0912	TUAAM	Base, antenna
102	Lead, electrical	5995-99-637-9538	TUAAM	Case, tuner RF
201	Cable assy.	5995-99-637-9887	Dist'n box	DCCU
401	Cable assy. PE	5995-99-117-7436	DCCU	RT-351 battery
601	Cable assy. PE	5995-99-637-0914	RT-351	Initiate box

Note: Cable 401 is supplied with the DCCU
Bonding lead illustrated as broken line

In this role the surf 4w, if fitted, must never be electrically connected to the radio.

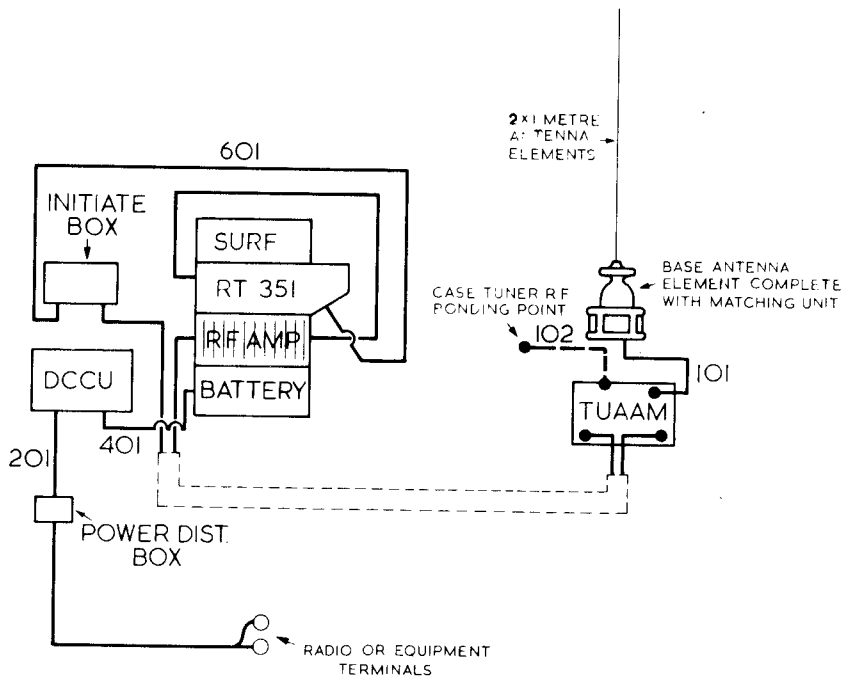

Fig. 14 Block schematic

BONDING

Note...

It is essential for the successful operation of this installation that the bonding instructions are followed exactly.

2.8 Bonding connections are shown in the block schematic fig. 14. Paint is to be removed from around the chosen bonding points down to bare metal. Details of bonding for wing-mounted equipment are given in para 2.5.

Section 3 TESTING

TESTING THE INSTALLATION

3.1 After the kits have been installed the following checks should be carried out:-

1. Inspect all fittings ensuring all nuts and screws are securely tightened.
2. Check that connectors are correctly fitted and are secured to vehicle or equipment rack to prevent accidental damage. Connector locking rings should be firmly tightened by hand.
3. Ensure the equipment is clean and dry.

TESTING THE RADIO EQUIPMENT

3.2 Check the radio equipment for serviceability as detailed in the appropriate User Handbook.

IDEAS SUGGESTIONS DEFECTS

YOU are the user of this equipment—can it be improved?

If you have any good suggestions about this or ANY Signals equipment, The Ministry of Defence Army Department are interested.

Ideas and Suggestions

If you can suggest:

- (a) *an improvement in design or shape,*
- (b) *a better method of installation, operating, or servicing,*
- (c) *other equipment which might do the job better,*

the procedure is quite simple—pass it to your OC or Adjutant for transmission to the local Chief Signal Officer.

It will remain YOUR idea.

See the Signal Equipment Performance Report (AF B63), details for completion of which are found on the cover of the pad.

Defects

If there is something wrong with the equipment AS IT STANDS, other than a fair wear and tear fault, it is a defect.

Again, don't keep it to yourself, pass it to your OC. The procedure for him to follow is given in EMER Management N200. (AFG 3660 is the form to use).

RESTRICTED

RESTRICTED